

Installation and Operation Manual

Thermo Scientific Revco® Chest and Upright Ultra-Low Temperature Freezers



© 2010 Thermo Fisher Scientific. All rights reserved.

“Suva[®]” is a registered trademark of DuPont.

Armaflex[®] is a registered trademark of Armacell International GmbH.

All other trademarks are the property of Thermo Fisher Scientific Inc. and its subsidiaries.

Table of Contents

1 About Legaci®	1
2 Safety Precautions	1
3 General Recommendations	1
3.1 Temperature Monitoring	1
3.2 General Operation	1
3.3 Initial Loading	1
4 Pre-Installation	2
4.1 Unpacking	2
5 Installation	2
5.1 Location	2
5.2 Wiring	2
5.3 Leveling	2
5.4 Door Operation (Upright Models)	3
5.4.1 Opening the Door	3
5.4.2 Closing the Door	3
5.5 Pressure Equalization Port	3
6 Operation (Revco Ultima II and Revco Elite Freezers)	4
6.1 Control Panel Features	4
6.2 Start Up	5
6.2.1 Turning the Power On	5
6.2.2 Setting the Cabinet Temperature	5
6.2.3 Setting the Alarms	5
6.2.4 Alarm Reset & Status Lights (Revco Ultima II and Elite Freezers)	5
6.2.5 Alarm Test (Revco Ultima II and Elite Freezers)	6
6.3 Backup System (Optional)	6
6.3.1 CO ₂ and LN ₂ Precautions	6
6.3.2 Installation	7
6.3.3 Operation	7
6.3.4 System Status Lights	7

7 Operation (Revco Value Series Freezers)	9
7.1 Control Panel Features	9
7.2 Start Up	9
7.2.1 Turning the Power On	9
7.2.2 Setting the Cabinet Temperature	9
7.2.3 Optional Alarm	9
8 Maintenance and Troubleshooting	10
8.1 Condenser Maintenance	10
8.1.1 Cleaning the Condenser	10
8.1.2 Cleaning the Condenser Filter	10
8.2 Gasket Maintenance	10
8.3 Defrosting the Freezer	10
8.4 Alarm Battery Maintenance	10
8.5 Troubleshooting Procedures	10
9 Chart Recorders	11
9.1 Set Up and Operation	11
9.2 Power Supply	11
9.3 Changing Chart Paper	11
9.4 Calibration Adjustment	11
10 Optional Equipment	12
10.1 Backup Protection Devices	12
10.1.1 Liquid Nitrogen (LN ₂)	12
10.1.2 Liquid CO ₂	12
10.1.3 Voltage Safeguard	12
10.2 Remote Alarm	12
11 Accessories	12

1 About Legaci®

All of the ultra-low temperature freezers described in this manual feature the Legaci® refrigeration system, a combination of advanced technologies designed specifically to provide optimal reliability in low-temperature applications.

Legaci systems include:

- Copeland compressors custom-designed for to minimize bearing wear and operate efficiently under heavy work loads
- DuPont Suva® refrigerants selected to provide maximum cooling capacity under low-temperature conditions
- A field-proven cascade refrigeration system design.

All upright models include a pressure equalization port to combat the vacuum created after door openings.

2 Safety Precautions

In this manual and on labels attached to this product, the words WARNING and CAUTION mean the following:

- **WARNING:** a potentially hazardous situation which, if not avoided, could result in serious injury or death.
- **CAUTION:** a potentially hazardous situation which, if not avoided, may result in minor or moderate injury or damage to the equipment.

Before installing, using or maintaining this product, please be sure to read this manual and product warning labels carefully. Failure to follow these instructions may cause this product to malfunction, which could result in injury or damage.

Below are important safety precautions that apply to this product:

- Use this product only in the way described in the product literature and in this manual. Before using it, verify that this product is suitable for its intended use.
- Do not modify system components, especially the controller. Use OEM exact replacement equipment or parts. Before use, confirm that the product has not been altered in any way.
- Your unit must be properly grounded in conformity with national and local electrical codes. Never connect the unit to overloaded power sources.
- Disconnect the unit from all power sources before cleaning, troubleshooting, or performing other maintenance on the product or its controls.

3 General Recommendations

3.1 Temperature Monitoring

IMPORTANT NOTE: *We recommend the use of a redundant and independent temperature monitoring system so that the freezer can be monitored continuously for performance commensurate with the value of product stored.*

3.2 General Operation

The refrigeration system is designed to maintain ultra-low temperatures with safety in a +32°C (90°F) ambient environment, **only** when the freezer is used for storage.



WARNING! This unit is not a “rapid-freeze” device. Freezing large quantities of liquid, or high-water content items, will temporarily increase the chamber temperature and will cause the compressors to operate for a prolonged time period.

Avoid opening the door for extended time periods since chamber temperature air will escape rapidly. Room air, which is higher in humidity, replacing chamber air may cause frost to develop in the chamber more rapidly.

3.3 Initial Loading

After reading and completing the Safety Considerations, Pre-Installation, Installation, and Operation sections of this manual, turn the Key Switch to the POWER ON position and adjust the temperature setpoint if necessary.

The setpoint should be no warmer than -50°C for two-stage freezers or -10°C for single-stage freezers. **Allow the freezer to operate at the desired temperature for a minimum of 12 hours before loading.**

If your freezer is an upright model, load the freezer one shelf at a time, beginning with the top shelf. After loading each shelf, allow the freezer to recover to the desired setpoint before loading the next shelf. Repeat this process until the freezer is fully loaded.



CAUTION! Failure to follow these procedures or overloading the unit may cause undue stress on the compressors or jeopardize user product safety.

4 Pre-Installation

4.1 Unpacking

At delivery, examine the exterior for physical damage while the carrier's representative is present. If exterior damage is present, carefully unpack and inspect the unit and all accessories for damage.

If there is no exterior damage, unpack and inspect the equipment within five days of delivery. If you find any damage, keep the packing materials and immediately report the damage to the carrier. Do not return goods without written authorization. When submitting a claim for shipping damage, request that the carrier inspect the shipping container and equipment.



CAUTION! Do not discard the sublids from chest-style units. The sublids are necessary to maintain correct temperature, moisture control, and economy of operation. Upright models do not include sublids as they utilize built-in metal inner doors.

5 Installation

Do not exceed the electrical and temperature ratings printed on the dataplate located on the lower left side of the unit.



CAUTION! Improper operation of the equipment could result in dangerous conditions. To preclude hazard and minimize risk, follow all instructions and operate within the design limits noted on the dataplate.

5.1 Location

Install the unit in a level area free from vibration with a minimum of six inches of space on the sides, rear, and top. Refer to Section 5.3 for further instructions on leveling cabinets. Allow enough clearance so that door or lid can swing open at least 90 degrees.

Do not position the equipment in direct sunlight or near heating diffusers, radiators, or other sources of heat. The ambient temperature range at the location must be 59 to 90°F (15 to 32°C).



CAUTION! To allow for proper air flow, a minimum of six inches of clearance space is required behind the freezer.

5.2 Wiring



CAUTION! Connect the equipment to the correct power source. Incorrect voltage can result in severe damage to the equipment.



CAUTION! For personal safety and trouble-free operation, this unit must be properly grounded before it is used. Failure to ground the equipment may cause personal injury or damage to the equipment. Always conform to the National Electrical Code and local codes. Do not connect the unit to overloaded power lines.

Your freezer is equipped with one of five NEMA style plugs (refer to Figure 1). These plugs meet UL requirements.

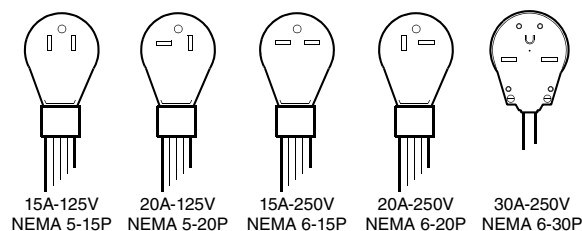

Figure 1. NEMA Style Plugs

Always connect the freezer to a dedicated (separate) circuit. Each freezer is equipped with a service cord and plug designed to connect it to a power outlet which delivers the correct voltage. Supply voltage must be within +10%, -5% of the freezer rated voltage.

If you have known voltage stability problems which are outside the limits of the freezer rated voltage, we recommended that the freezer be equipped with a Voltage Safeguard. Order the Voltage Safeguard (refer to Section 10.1.3 on page 12 for ordering information).

Note: *Revco Ultima II Series freezers are equipped with a standard built-in Voltage Safeguard circuit to detect and adjust low line voltage.*



CAUTION! Never cut the grounding prong from the service cord plug. If the prong is removed, the warranty is invalidated.

5.3 Leveling

The unit must be level both front to back and side to side.

To level chest models, leave the casters in place and shim the low wheel(s) with strips of sheet metal cut at least 1/2 in. wider than the caster.

Upright models have adjustable leveling feet which are located adjacent to the front casters.

5.4 Door Operation (Upright Models)

Upright freezer models are equipped with an advanced Cryolatch™ assembly specifically designed for ultra-low temperature freezers.

Features include:

- One-hand operation
- A front-accessible lock, keyed to match the freezer control lock
- Hasps for a standard padlock to provide additional security
- Durable construction for reliable operation and safe product storage.



CAUTION! When moving the freezer, always grasp cabinet surfaces; never pull the freezer by the latch handle.

5.4.1 Opening the Door

1. Remove the padlock if you have one.
2. Move the key into the open position by rotating it counter-clockwise.
3. Grasp the latch handle (preferably with your left hand) and pull it toward yourself until the latch disengages from the cabinet strike.
4. Keep pulling by the latch handle or the integrated door handle to open the main door.

5.4.2 Closing the Door

Note that the latch does not self-engage automatically when you close the door. You must rotate the latch into the open position first.

1. Grasp the latch handle (preferably with your left hand) and pull it toward yourself, rotating the latch into the open position.
2. Move the freezer door into the closed position and gently push the handle away from you, making sure that the latch engages fully with the cabinet strike.



CAUTION! Closing the door without making sure the latch engages fully with the strike can result in substantial prying forces on the door.

3. Keep applying gentle pressure to the latch handle until the latch is securely in closed position.
4. Insert the key and rotate clockwise to lock.
5. Replace the padlock if you are using one.

5.5 Pressure Equalization Port

When an upright ultra-low temperature freezer door is opened, room temperature air rushes into the storage compartment. When the door is closed, the fixed volume of air is cooled rapidly. Pressure drops below atmospheric pressure, resulting in a substantial vacuum. Re-entry into the cabinet is impossible until internal pressures are returned to atmospheric pressure. Without a pressure equalization mechanism, it can take several minutes before the door can easily be reopened.

All upright models feature a port that provides vacuum relief after door openings.

The pressure equalization port is located in the bottom left side of the storage chamber. Although the port is designed to self-defrost, excessive frost accumulation in the bottom of the chamber could eventually restrict air flow. Therefore you should periodically inspect the port and brush away any loose frost using a stiff nylon brush.



WARNING! To ensure proper operation, be sure not to obstruct the port. Push any storage racks near the port all the way to the rear of the cabinet.



WARNING! When the freezer is in operation, avoid touching the lower left side of the cabinet exterior near the “hot surface” warning label. The port can get hot immediately after it is activated.

6 Operation (Revco Ultima II and Revco Elite Freezers)

6.1 Control Panel Features

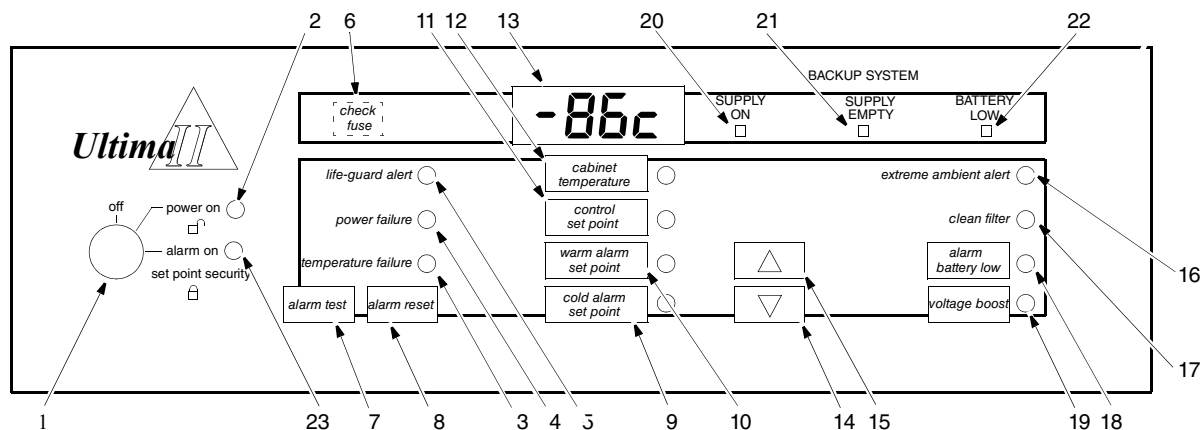

Figure 2. Revco Ultima II Series Control Panel with Optional Backup System

Before the initial start up, take some time to become familiar with the controls on your freezer. Figure 2 illustrates the Revco Ultima II Chest and Upright Freezer control panel.

Note: *Figure 2 shows all possible functions. These functions vary depending on the model and options. You may not have all of the functions on your equipment. Revco Elite models do not include the Check Fuse indicator light (6) or the Voltage Boost light (19) as these models do not come standard with these options. Likewise, **only** Revco Ultima II models will include the Set Point Security feature (23), Life-Guard Alert indicator light (5), and the Extreme Ambient Alert indicator light (16). The CO₂ or LN₂ Backup System lights (20, 21, 22) represent status indicators for a built-in CO₂ or LN₂ backup system, which is optional on Revco Ultima II and Elite models.*

1. Three position keyed Power On Switch.
2. Power On Indicator. This indicator lights when power is connected to the freezer.
3. Temperature Failure Indicator. This indicator lights when the freezer temperature deviates either above or below the alarm temperature settings.
4. Power Failure Indicator. This indicator lights when there is a power failure to the freezer (refer to Section 8 on page 10).
5. Life-Guard Alert Indicator (Revco Ultima II Models only.) This indicator lights when the first stage compressor has gone into a cautionary state of operation to help prevent failure.
6. Check Fuse Light (Revco Ultima II and Ultima Models only). This indicator lights when the surge protector on the main electronic panel is blown by a power surge (refer to Section 8 on page 10).
7. Alarm Test Pad. Press this pad to start an alarm test (refer to Section 5.2.5 on page 6).
8. Alarm Reset Pad. Press this pad to reset *slowly* blinking indicators. Slowly blinking indicators denote that the condition *has* occurred but is now within the given operating parameters. This pad is also depressed to temporarily silence the audible alarm (refer to Section 6.2.4 on page 5).
9. Cold Alarm Setpoint. Press this pad to set the cold alarm (refer to Section 6.2.3 on page 5).
10. Warm Alarm Setpoint. Press this pad to set the warm alarm (refer to Section 6.2.3 on page 5).
11. Control Setpoint. Press this pad to set the cabinet temperature (refer to Section 6.2.2 on page 5).
12. Cabinet Temperature Indicator. This indicator lights when the temperature display window is showing the cabinet temperature (refer to Section 6.2.1 on page 5).
13. Digital Temperature Display Window. This window displays chamber temperature, alarm values, etc. depending on the operating status of the freezer and the procedure being performed.
14. Decrement Pad (▽). Use this pad to decrease temperature values.
15. Increment Pad (△). Use this pad to increase temperature values.
16. Extreme Ambient Alert (Revco Ultima II Models only). This indicator lights when the ambient temperature has exceeded the upper limit of the recommended operating range. If the Extreme Ambient Alert is activated, the ambient environment needs to be improved for proper function of the freezer.
17. Clean Filter Indicator. This indicator lights when the air cooled condenser filter is dirty (refer to Section 8 on page 10).
18. Alarm Battery Low Indicator. This indicator lights when the charge on the alarm battery is low. Press this button to display the percent of full battery charge in the digital display window.
19. Voltage Boost Indicator. This indicator lights when incoming voltage is low and the Voltage Safeguard has been activated (refer to Section 8 on page 10). Press this pad to display the current line voltage in the digital display window.
20. Backup System Supply On Indicator.
21. Backup System Supply Empty Indicator.
22. Backup System Battery Low Indicator.
23. Alarm On/Set Point Security Indicator. This indicator lights when the alarm is activated. Also indicates that Setpoint Security is activated (Revco Ultima II Models only).

The following indicators are available only when the freezer is equipped with the optional backup system (refer to Section 6.3.4 on page 7).

20. Backup System Supply On Indicator.
21. Backup System Empty Indicator
22. Backup System Battery Low Indicator.

6.2 Start Up

Refer to Section 6.1 and Figure 2 on page 4 as you complete the following procedures.

6.2.1 Turning the Power On

To start up the Revco Ultima II, Ultima, and Elite Series Freezers, complete the following steps:

1. Plug the freezer into the power outlet (refer to Section 4.2 on page 2).
2. Turn the key switch to the POWER ON position. The Power On LED and the Cabinet Temperature LED illuminate.

Note: *The alarm function is not active at this time. Refer to Section 5.2.3 for information about setting the alarms. In addition, for Revco Ultima II units only, the Setpoint Security will be deactivated in this key position.*

6.2.2 Setting the Cabinet Temperature

To set the cabinet temperature, complete the following steps:

1. For Revco Ultima II units, press and hold the Control Setpoint pad.
2. The Control setpoint LED lights and the Cabinet Temperature LED goes out.
3. Press and hold \triangle to increase the temperature or ∇ to decrease the temperature. The digital display scrolls through temperature settings.
4. Release both pads when the digital temperature display window shows the correct setpoint value.

Note: *If no keys are pressed within ten seconds, the temperature display reverts to the cabinet temperature.*

6.2.3 Setting the Alarms

To set the cold alarm, complete the following steps:

1. For Revco Ultima II units only, confirm that the key switch is at the Power On position (Setpoint Security disabled)
2. Press and hold the Cold Alarm Setpoint pad. The LED next to this pad lights. The temperature display shows the Cold Alarm value.
3. Press and hold \triangle or ∇ to adjust the Cold Alarm Setpoint.
4. Release both pads when the digital temperature display window shows the correct setpoint value.

To set the warm alarm, complete the following steps:

1. For Revco Ultima II units only, confirm that the key switch is at the Power On position (Setpoint Security disabled).
2. Press and hold the Warm Alarm Setpoint pad. The LED next to this pad lights. The temperature display shows the Warm Alarm value.

3. Press and hold \triangle or ∇ to adjust the Warm Alarm Setpoint.
4. Release both pads when the digital temperature display window shows the correct setpoint value.

When the cabinet temperature drops below the Warm Alarm setting, turn the key switch to ALARM ON. The freezer is ready to operate.

Note: *If a power failure lasting over 30 seconds occurs, the POWER ON light goes out, the POWER FAILURE light and digital temperature display flash simultaneously, and a buzzer sounds.*



WARNING! You must turn the three-position key switch to the ALARM ON/SETPOINT SECURITY position to activate the alarm and place it in security operation.

6.2.4 Alarm Reset & Status Lights (Revco Ultima II and Elite Freezers)

The alarm reset feature ensures user acknowledgment of the occurrence of certain alarm conditions. This provides greater monitoring power by alerting the user if an alarm condition has occurred during periods when the freezer must be left unattended. The alarm conditions incorporating this feature are:

- Temperature Failure-Warm Alarm
- Temperature Failure-Cold Alarm
- Voltage Low
- Power Failure
- Life-Guard Alert (Revco Ultima II only)
- Extreme Ambient Alert (Revco Ultima II only)

During any of these alarm conditions, the corresponding indicator will flash quickly, approximately 90 times per minute. If the alarm condition then disappears, the flash rate will decrease to approximately 15 times per minute. The indicator will then remain flashing at this rate, unless the condition reoccurs, until the Alarm Reset button is pressed. Once this has occurred, the indicator will no longer be lit.

In the case of TEMPERATURE FAILURE-WARM ALARM and TEMPERATURE FAILURE-COLD ALARM, if these conditions have occurred but are now within the given limits, the two indicators will alternately flash (180° out of phase). In addition, for these two temperatures failures, the highest temperature and lowest temperature, respectively, during the error condition will be saved. Prior to the temperature failure being reset, the temperature extreme may be viewed by pressing the Cabinet Temperature pad in conjunction with either the Warm Alarm Setpoint pad or the Cold Alarm Setpoint pad.

Note: *Once the Alarm Reset button is depressed, the extreme temperature value is reset to the current cabinet temperature.*

6.2.5 Alarm Test (Revco Ultima II and Elite Freezers)

To test the cold and warm alarms, complete the following steps:

1. Press and hold the Alarm Test pad. The digital temperature display indicates rising temperature. When the temperature reaches the warm alarm value, the alarm sounds.

Note: *The temperature of the refrigerated space does not change during this procedure. Only the sensor is heated.*

2. Release the Alarm Test pad, the sensor and display return to cabinet temperature in a few minutes.

You can press the Audio Silence pad to silence the alarm but the alarm will ring back in five to seven minutes. You can silence the alarm in this manner as many times as necessary until the sensor cools below the warm alarm temperature. The alarm quits automatically when the sensor cools below the warm alarm value.

Note: *There is a limit on the alarm test feature. The alarm test will not commence if the warm alarm setpoint is more than 15 degrees warmer than the operating temperature setpoint.*

6.3 Backup System (Optional)

When you purchase a built-in CO₂ or LN₂ optional backup system for the freezer, the backup system control panel is located behind a hinged panel adjacent to the grill (refer to Figure 3).

Note: *Always purchase the cylinders which are equipped with siphon tubes for withdrawing liquid from the bottom of the cylinder. CO₂ cylinders must be kept at room temperature to function properly. LN₂ bottles are functional at any reasonable temperature.*

Use this panel to set the backup initiation temperature, usually 10 to 15°C warmer than the operating setpoint.

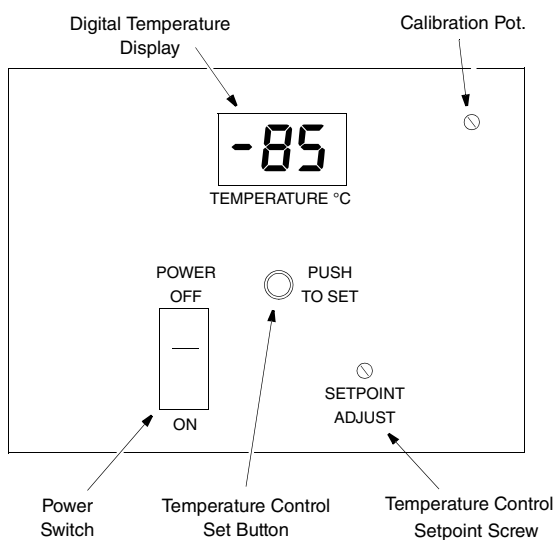

Figure 3. Control Panel for Optional Built-In Backup System

Note: *Revco Value Series units use free-standing, field installed Backup Systems.*

6.3.1 CO₂ and LN₂ Precautions

The following are precautions for using liquid CO₂ and LN₂ backup systems.



WARNING! If a CO₂ or LN₂ cylinder falls and a valve is knocked off, the cylinder becomes a deadly and completely unguided missile. Transport the cylinders in a handtruck or cart with secure chain ties for the cylinder. After cylinders are connected to the equipment, securely attach them with chains to a solid, stationary object such as a building column.



WARNING! CO₂ and LN₂ liquids are non-poisonous but are very cold and will burn unprotected skin. Always wear protective eyewear and clothing when changing cylinders or working on the piping systems attached to an active source of liquid refrigerant.



WARNING! The gases produced by evaporation of CO₂ or LN₂ are non-poisonous but displace the oxygen in a confined space and can cause asphyxiation. **Do not store the cylinders in subsurface or enclosed areas.**



CAUTION! When closing the cylinder valve, make sure that the injection solenoid is energized to allow all the liquid to bleed off instead of being trapped in the supply tubing. Failure to do this results in activation of the pressure relief device, which could damage the freezer and requires replacing if it is activated.



CAUTION! For chest and upright models ordered with factory installed built-in backup systems, the flow of liquid CO₂ or LN₂ will be discontinued if the door or lid is opened during operation of the backup system. For units operated with free-standing, field installed type backup system, the flow of liquid CO₂ or LN₂ will be discontinued upon door or lid opening **only** if the switch provided with the free-standing package is installed on the freezer.

6.3.2 Installation

Field installed systems are supplied with complete installation and operating instructions. If your system is factory installed, the freezer is shipped with a coiled length of tubing to connect the freezer to the bottles:

- 3/8 in. OD copper tubing for connection to the CO₂ supply.
- 5/8 in. OD copper tubing covered with Armaflex[®] insulating tubing for connection to the LN₂ supply.

Straighten the coiled tubing and connect one end to the labeled connection on the freezer and the other end to the supply bottle or building supply fitting.

6.3.3 Operation

To activate the optional backup system, complete the following steps:

1. Push the Power Switch to the ON position. The digital temperature display window shows the current cabinet temperature.
2. Press and hold the Push to Set button to display the setpoint temperature in the digital temperature display window.
3. Use a small screwdriver to rotate the Setpoint Adjust screw until the correct backup operating temperature shows in the display window. The recommended setpoint is 10 to 15°C above normal cabinet temperature.

Note: The temperature shown in the display window is accurate to ±1°C.

The backup system can run for a minimum of eight hours on battery power.



WARNING! You must push the Power Switch to the ON position in order to activate the backup system.

6.3.4 System Status Lights

In addition to the backup control system, the built-in backup system includes main control panel system status lights. These lights are only available when the backup system is installed.

- The Supply On Indicator lights when the backup system is operating on battery power.
- The Backup System Battery Low Indicator lights when the backup system battery charge is low. The built-in battery charger recharges the battery to full charge when power is restored to the system.

Note: Since rechargeable batteries degrade over time, the battery should be replaced after approximately three years.

- The Backup System Empty Indicator lights when the standby CO₂ or LN₂ bottle is empty.

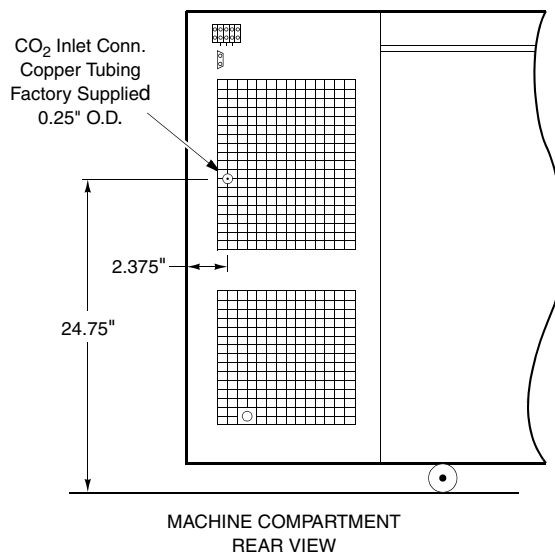

Figure 4. Location of CO₂ Connection Site, Chest Models Only

Table 1. Backup System Flow Rates – Cryogenic Freezers

Center Air Temperature	Lbs/hr @ 75°F Ambient Temperature (Flow Rate)				
	-150×C	-140×C	-130×C	-120×C	
Liquid LN₂					
Chest Freezers					
5 ft ³	Empty	11.0	9.5	8.4	7.3
	1/2 Full	9.3	8.0	7.0	6.1
	Full	6.5	5.9	5.1	4.5
7 ft ³	Empty	11.3	10.0	9.0	8.0
	1/2 Full	9.7	8.6	7.6	6.8
	Full	7.8	6.8	6.0	5.2
10 ft ³	Empty	15.2	13.5	11.9	10.3
	1/2 Full	12.0	10.4	9.4	8.3
	Full	8.9	7.8	7.0	6.1

Table 2. Backup System Flow Rates

Center Air Temperature		Lbs/hr @ 75°F Ambient Temperature (Flow Rate)		
		-50°C	-60°C	-70°C
Liquid CO₂				
Chest Freezers				
3 ft ³	Empty	2.83	2.96	3.1
	1/2 Full	2.4	2.7	3.1
	Full	1.8	2.1	2.4
7 ft ³	Empty	4.1	4.7	5.5
	1/2 Full	3.5	4.0	4.6
	Full	2.6	3.0	3.5
10 ft ³	Empty	4.9	5.6	6.6
	1/2 Full	4.2	4.8	5.5
	Full	3.1	3.6	4.1
14 ft ³	Empty	5.6	6.5	7.5
	1/2 Full	4.8	5.5	6.3
	Full	3.5	4.2	4.8
17 ft ³	Empty	6.5	7.5	8.7
	1/2 Full	5.5	6.3	7.3
	Full	4.1	4.8	5.5
20 ft ³	Empty	7.3	8.4	9.8
	1/2 Full	6.2	7.1	8.2
	Full	4.6	5.4	6.2
Upright Freezers				
13 ft ³	Empty	7.4	8.5	9.7
	1/2 Full	6.5	7.4	8.3
	Full	5.1	5.9	6.7
17 ft ³	Empty	8.3	9.5	10.9
	1/2 Full	7.3	8.3	9.3
	Full	5.8	6.6	7.5
21 ft ³	Empty	8.9	10.2	11.7
	1/2 Full	7.8	8.9	10.0
	Full	6.2	7.1	8.1
25 ft ³	Empty	9.5	10.9	12.5
	1/2 Full	8.3	9.5	10.7
	Full	6.6	7.6	8.7

Center Air Temperature		Lbs/hr @ 75°F Ambient Temperature (Flow Rate)		
		-60°C	-70°C	-80°C
Liquid LN₂				
Chest Freezers				
3 ft ³	Empty	2.7	3.1	3.5
	1/2 Full	2.2	2.6	2.9
	Full	1.7	1.9	2.2
7 ft ³	Empty	3.9	4.5	4.1
	1/2 Full	3.3	3.8	4.3
	Full	2.5	2.8	3.2
10 ft ³	Empty	4.7	5.4	6.1
	1/2 Full	4.0	4.5	5.1
	Full	3.0	3.4	3.8
14 ft ³	Empty	5.4	6.2	7.0
	1/2 Full	4.5	5.2	5.9
	Full	3.4	3.9	4.4
17 ft ³	Empty	6.2	7.1	8.1
	1/2 Full	5.3	6.0	6.8
	Full	3.9	4.4	5.1
20 ft ³	Empty	7.0	8.0	9.1
	1/2 Full	5.9	6.7	7.6
	Full	4.4	5.0	5.7
Upright Freezers				
13 ft ³	Empty	7.0	7.9	8.9
	1/2 Full	6.1	6.8	7.6
	Full	4.8	5.4	6.1
17 ft ³	Empty	7.7	8.7	9.8
	1/2 Full	6.7	7.5	8.4
	Full	5.3	5.9	6.7
21 ft ³	Empty	8.4	9.5	10.7
	1/2 Full	7.3	8.2	9.2
	Full	5.8	6.5	7.3
25 ft ³	Empty	9.1	10.3	11.6
	1/2 Full	7.9	8.9	10.0
	Full	6.3	7.1	7.9

7 Operation (Revco Value Series Freezers)

7.1 Control Panel Features

Before the initial start up, take some time to become familiar with the controls on your freezer. Figure 5 illustrates the Revco Value Series Chest and Upright Freezer control panel.

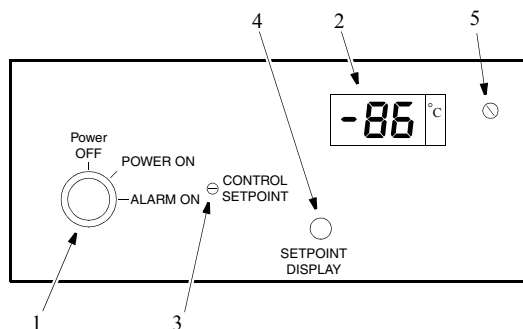

Figure 5. Revco Value Series Control Panel (Shown with Optional Alarm)

1. Keyed Power On/Alarm On switch.
2. LED digital temperature display.
3. Recessed temperature control setpoint adjustment.
4. Temperature setpoint adjust button.
5. Calibration potentiometer.

7.2 Start Up

Refer to Figure 5 as you complete the following procedures.

7.2.1 Turning the Power On

To start up the Revco Value Series Freezers, complete the following steps:

1. Plug the freezer into the power outlet (refer to Section 5.2 on page 2).
2. Turn the key switch to the POWER ON position. The digital temperature display shows “00” until the unit cools down to -1°C; after that, the actual cabinet temperature is displayed.

Note: *The alarm function is active at this time, but the alarm will only sound when the key is turned to the Alarm position.*

7.2.2 Setting the Cabinet Temperature

To set the cabinet temperature, complete the following steps:

1. Insert a small screwdriver into the slotted screw labeled Control Setpoint and simultaneously press and hold the Setpoint Display button. The temperature display changes to read the existing setpoint value.
2. Turn the setpoint screw (clockwise for a colder setting and counterclockwise for a warmer setting) until the desired setpoint shows in the digital temperature display.
3. Release the Setpoint Display button. The digital temperature display returns to the cabinet temperature.

7.2.3 Optional Alarm

The optional Revco Value Series Alarm is operated by the freezer electronic control system. The alarm is preset at the factory with a warm alarm setpoint:

- For units designed to operate at -75°C and -85°C, the alarm setpoint is approximately 90% of the freezer temperature setpoint. For example, if the freezer setpoint is -80°C, the alarm setpoint is -72°C.
- For units designed to operate at -50°C and warmer, the alarm setpoint is 80% of the freezer temperature setpoint. For example, if the freezer setpoint is -45°C, the alarm setpoint is -36°C.

To activate the alarm, wait until the freezer reaches operating temperature and turn the key switch to the ALARM ON position.



WARNING! You must turn the three-position key switch to the ALARM ON position to activate the alarm and place it in operation.

8 Maintenance and Troubleshooting



WARNING! Unauthorized repair of your freezer will invalidate your warranty. Contact Technical Service at 1-800-438-4851 for additional information.



CAUTION! Maintenance should only be performed by trained personnel.

8.1 Condenser Maintenance

8.1.1 Cleaning the Condenser

Clean the condenser at least every six months; more often if the laboratory area is extremely dust prone.

To clean the condenser, complete the following steps:

1. Pull the grill open.
2. Remove the filter. Check the fans. If a fan is not operating, contact an Authorized Service Company immediately.
3. Vacuum the condenser.
4. Replace the filter and close the grill.

8.1.2 Cleaning the Condenser Filter

Clean the condenser filter every two or three months.

1. Pull the grill open.
2. Remove the filter.
3. Shake the filter to remove loose dust, rinse the filter in clean water, shake the excess water from the filter, and replace the filter.
4. Close the grill.

8.2 Gasket Maintenance

Periodically check the gaskets around the door or lid for punctures or tears. Leaks are indicated by a streak of frost which forms at the point of gasket failure. Make sure that the cabinet is level (refer to Section 5.3 on page 2 for leveling information).

Keep the lid and door gaskets clean and frost free by wiping gently with a soft cloth.

8.3 Defrosting the Freezer

Defrost the freezer once or year or whenever the ice buildup exceeds 3/8”.

To defrost, complete the following steps:

1. Remove all products and place in another cabinet.
2. Turn off the freezer.
3. Open the outer door and all inner doors.
4. Let the freezer stand with doors open for at least 24 hours. This allows both the interior and foamed refrigerant system to warm to room temperature.
5. Dispose of the ice and wipe out any water standing in the bottom of the cabinet.
6. If there is freezer odor, wash the interior with a solution of baking soda and warm water. Clean the exterior with any common household cleaning wax.
7. Close the doors, restart the freezer and reload, following the instructions in Section 3.3 on page 1.

8.4 Alarm Battery Maintenance

Have a technician check the condition of the alarm battery at least once a year.

To replace the alarm battery, complete the following steps:

1. Pull open the front grill. The alarm battery is located directly behind the grill. The terminals are the “push on” type.
2. Grasp the terminal with pliers and work it gently back and forth while pulling it off. The fittings are tight.
3. Remove the battery and put the new battery in place.

Note: *You may have to cut a strip of silicone rubber in order to remove the battery.*

4. Connect the battery terminals and replace the front grill.

8.5 Troubleshooting Procedures

Table 3. Troubleshooting Procedures

Problem	Solution
Check Fuse indicator is on.	Surge protector is blown. Call an Electronics Technician to check the equipment.
Clean Filter indicator is on.	Condenser filter is dirty. Refer to Section 8.1.2.
Alarm Battery Low indicator is on.	Alarm battery is low on charge. Have a technician check the alarm battery. Refer to Section 8.4.
Voltage Boost indicator is on.	Low incoming line voltage to the freezer. Call an Electronics Technician to check the power supply.

9 Chart Recorders

Panel-mounted six-inch seven-day recorders are available as options for all freezer models.

9.1 Set Up and Operation

To prepare the recorder to function properly, complete the following steps:

1. Open the recorder door to access the recorder.
2. Connect the nine volt DC battery located at the recorder's upper right corner. This battery provides backup power.
3. Install clean chart paper (refer to Section 9.3 below).
4. Remove the plastic cap from the pen stylus and close the recorder door.

Recorder operation begins when the system is powered on. The recorder may not respond until the system reaches temperatures within the recorder's range.

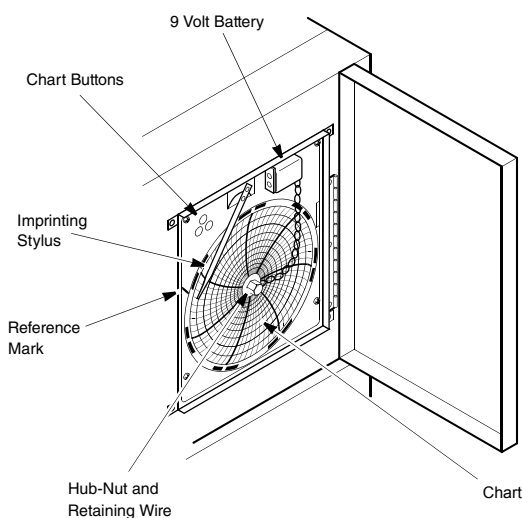

Figure 6. Chart Recorder

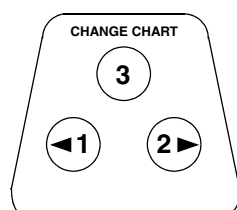

Figure 7. Chart Buttons



CAUTION! Do not use sharp or pointed objects to depress the chart buttons. This may cause permanent damage to the recorder.

9.2 Power Supply

The recorder normally uses AC power when the system is operating. If AC power fails, the LED indicator flashes to alert you to a power failure. The recorder continues sensing cabinet temperature and the chart continues turning for approximately 24 hours with back-up power provided by the nine-volt battery.

The LED indicator glows continuously when main power is functioning and the battery is charged.

When the battery is low, the LED flashes to indicate that the battery needs to be changed.

9.3 Changing Chart Paper

To change the chart paper, complete the following steps:

1. Locate the pressure sensitive buttons at the front, upper left of the recorder panel.
2. Press and hold the Change Chart button (#3) for one second. The pen will move off the scale.
3. Unscrew the center nut, remove the old chart paper, and install new chart paper. Carefully align the day and time with the reference mark (a small groove on the left side of the recorder panel).
4. Replace the center nut and hand tighten. Press the Change Chart button again to resume temperature recording.

9.4 Calibration Adjustment

This recorder has been accurately calibrated at the factory and retains calibration even during power interruptions. If required, however, adjustments can be made as follows:

1. Run the unit continuously at the control setpoint temperature. Continue steady operation for at least two hours to provide adequate time for recorder response.
2. Measure cabinet center temperature with a calibrated temperature monitor.
3. Compare the recorder temperature to the measured cabinet temperature. If necessary, adjust recorder by pressing the left (#1) and right (#2) chart buttons.

Note: The stylus does not begin to move until the button is held for five seconds.

10 Optional Equipment

In addition to the optional chart recorder, the following equipment is available for some freezer models. Refer to the Accessories section on page 12 for more information on these and other options, including inventory racks and storage boxes.

For additional information, contact your dealer or Customer Sales at 1-800-252-7100.

10.1 Backup Protection Devices

Liquid Nitrogen and Liquid CO₂ systems are available to protect your product in case of a prolonged power failure. These systems are powered by a rechargeable battery with a built-in automatic charger. Refer to Section 6.3.4 on page 7 for additional information.

10.1.1 Liquid Nitrogen (LN₂)

This system uses portable and locally refillable bottles. These containers keep the liquid at low temperature and pressure by continually venting a small amount of gaseous N₂. You must check the liquid level indicator daily to assure an adequate emergency supply.

10.1.2 Liquid CO₂

This system uses portable and locally refillable bottles that are not vented and have a virtually unlimited standby life unless they develop a leak. These containers hold liquid at room temperature and high pressure. Several bottles can be connected together, increasing the effective length of standby refrigeration.

10.1.3 Voltage Safeguard

This fully automatic device monitors the supply voltage and increases voltage if necessary so the freezer always operates within the factory recommended limits. Revco Ultima II models are factory equipped with this device.

CAUTION! The Voltage Safeguard unit does not allow you to operate a 115 volt product on 230 volts or vice versa. It is designed to provide 5 to 15% voltage correction, depending on the freezer model.

10.2 Remote Alarm

The remote alarm terminals on the back of the freezer are connected to freezer internal dry contacts. You can connect a remote alarm package with a separate 24 volt power supply.

11 Accessories

Note: For accessories and options not described herein, or for special modifications, contact Customer Sales.

Inventory Rack Capacity Chart for Revco Ultima, Elite, and Value Series

Rack Catalog No. (Rack Quantity) Box Size in.	Cubic Foot Capacity											
	1	3.1	4.5	6.8	10.3	13.7	17.1	20.5	13.4	17.2	20.2	24.4
For ULT Chest Freezers												
5972, Full Rack, (7) 2 in. boxes	—	9	12	—	—	—	—	—	—	—	—	—
5973, Full Rack, (5) 3 in. boxes	—	9	12	—	—	—	—	—	—	—	—	—
5978, Full Rack, (11) 2 in. boxes	—	—	—	12	18	24	30	36	—	—	—	—
6096, Full Rack, (8) 3 in. boxes	—	—	—	12	18	24	30	36	—	—	—	—
6230, Half Rack, (6) 2 in. boxes	—	—	—	24	36	48	60	72	—	—	—	—
6231, Half Rack, (4) 3 in. boxes	—	—	—	24	36	48	60	72	—	—	—	—
For ULT Upright Freezers												
6112-1, (12) 2 in. or (9) 3 in. boxes	—	—	—	—	—	—	—	—	20	—	—	—
6113-1, (16) 2 in. or (12) 3 in. boxes	—	—	—	—	—	—	—	—	—	20	25	30

Inventory Component Description, Ultra-Low Temperature Freezers

Description	Catalog No.
For All Models	
Fiberboard boxes and grid dividers are packaged in lots of one dozen	
Fiberboard box, 5-1/4 in. square x 2 in. high, one dozen.	5954
Fiberboard box, 5-1/4 in. square x 3 in. high, one dozen.	5956
Grid divider, fiberboard, 100 cell, 7/16 in., holds 100 12 mm vials, one dozen.	5958
Grid divider, fiberboard, 49 cell, 5/8 in., holds 49 16 mm vials, one dozen.	5959
Grid divider, fiberboard, 64 cell, 9/16 in., holds 64 14 mm vials, one dozen.	5960
Grid divider, fiberboard, 81 cell, 1/2 in., holds 81 13 mm vials, one dozen.	6212
Stainless steel box, 5-1/4 in. square x 2 in. high, each.	5955
Stainless steel box, 5-1/4 in. square x 3 in. high, each.	5957
Stainless steel box cover, each.	5953
For Chest Models	
Single full rack, holds (7) 2 in. boxes, for 3.1 and 4.5 cu.ft chest models only.	5972
Single full rack, holds (5) 3 in. boxes, for 3.1 and 4.5 cu.ft chest models only.	5973
Single full rack, holds (11) 2 in. boxes, for all chest models except 3.1 and 4.5 cu.ft.	5978
Single full rack, holds (8) 3 in. boxes, for all chest models except 3.1 and 4.5 cu.ft.	6096
Single full rack, holds (8) plasma boxes, for 3 cu.ft chest model.	6097
Single full rack, holds (13) plasma boxes, for all chest models except 3.1 and 4.5 cu.ft.	6098
Single split rack, holds (6) 2 in. boxes, for all chest models except 3.1 and 4.5 cu.ft.	6230
Single split rack, holds (4) 3 in. boxes, for all chest models except 3.1 and 4.5 cu.ft.	6231
Basket/Rail Kit, for 6.8 cu.ft chest freezers.	6217
Basket/Rail Kit, for 10.3 cu.ft chest freezers.	6218
Basket/Rail Kit, for 13.7 cu.ft chest freezers.	6190
Basket/Rail Kit, for 17.1 cu.ft chest freezers.	6191
Basket/Rail Kit, for 20.5 cu.ft chest freezers.	6192

Description	Catalog No.
For Upright Models	
Adjustable single stack, holds (12) 2 in. or (9) 3 in. boxes, for 13.4 cu.ft upright models.	6112-1
Adjustable single stack, holds (16) 2 in. or (12) 3 in. boxes, for 17.2, 20.2, and 24.4 cu.ft upright models.	6113-1
Solid stainless steel shelf:	
for 13.4 cu.ft upright models only.	6667
for 17.2 cu.ft upright models only.	6668
for 20.2 cu.ft upright models only.	6669
for 24.4 cu.ft upright models only.	6670

Inventory Components, Blood Bank Red Cell and Plasma Freezers

Description	Catalog No.
Plasma Rack, single, holds (13) plasma boxes, for all chest models.	6098
Plasma Rack, single, holds (12) plasma boxes, for 13.4 cu.ft upright models.	6110-1
Plasma Rack, single, holds (16) plasma boxes, for 17.2 and 20.2 cu.ft upright models.	6111-1
Red cell press.	6225

Blood Bank Freezer Inventory Capacity

Rack Catalog No. and Description ^a	Freezers Cu.ft/Total Capacity				
	Chest			Upright	
	6.8 Cu.ft	13.7 Cu.ft	20.5 Cu.ft	13.4 Cu.ft	20.2 Cu.ft
6225, Red Cell Press.	92	204	334	200	—
6098, Plasma Rack, 13 Box Capacity.	12	24	36	—	—
6110-1, Plasma Rack, 12 Box Capacity.	—	—	—	20	—
6111-1, Plasma Rack, 16 Box Capacity.	—	—	—	—	25

^a Example: A 13.7 cu.ft plasma chest freezer holds 24 total Catalog No. 6098 Plasma Racks.

Temperature Recorders

All six inch recorders utilize pressure-sensitive chart paper (1 box @ 50 charts included), no inking is required except Catalog No. 6183 which utilizes an inked pen. .

Description	Catalog No.
Temperature recorder, 6 in. circular chart, seven-day drive, panel mounted. Factory installed.	6171
Temperature recorder, 6 in. circular chart, seven-day drive, for -120°C, -140°C, and -150°C models only, panel mounted. Factory installed.	6183
Temperature recorder, 6 in. circular chart, seven-day drive, free-standing, for all ULT freezers -40°C to -90°C. Customer installed.	6170
Temperature recorder, 6 in. circular chart, seven-day drive, free-standing, for -120°C, -140°C, and -150°C models only. Customer installed.	6236

Chart Paper

Description	Catalog No.
Chart paper, package of 50, for 6 in., seven-day recorder, -115°C to +50°C.	6185
Chart paper, package of 50, 6 in., seven-day recorder, -150°C to +20°C.	6186

Special Voltages

Standard voltages are listed under *Voltage* in Specification Charts associated with each product category. Standard voltages are available at no charge; alternative voltages may be available at an extra charge. All voltages must be specified when ordering. Contact Customer Sales for more information.

Electronic Backup Systems

CO₂ Backup System. Choose built-in or free-standing. Injects liquid CO₂ into cabinet when cabinet temperature warms to pre-set level. Automatic shut-off on door or lid opening. Adjustable CO₂ setpoint in 1°C increments to -75°C with digital display and actual cabinet temperature at the push of a button. Indicator lights when system is activated. System is powered by continually recharged battery. Includes all hardware except CO₂ cylinder.

Description	Catalog No.
CO ₂ Backup, built-in, panel mounted, factory installed. Revco Ultima and Elite only. Low battery indicator lights when battery needs replacing. Empty cylinder indicator lights when cylinder is exhausted.	6594
CO ₂ Backup, free-standing, field installed. Specify freezer model number and voltage when ordering.	6593

LN₂ Backup System. Choose built-in or free-standing. Injects liquid nitrogen into cabinet when cabinet temperature warms to pre-set level. Automatic shut-off on door or lid opening. Adjustable LN₂ setpoint in 1°C increments to -150°C with digital display and actual cabinet temperature at the push of a button. Indicator lights when system is activated. System is powered by continually recharged battery. Includes all hardware except low-pressure liquid nitrogen cylinder.

Description	Catalog No.
LN ₂ Backup, built-in, panel mounted, factory installed. Revco Ultima and Elite only. Low battery indicator lights when battery needs replacing. Empty cylinder indicator lights when cylinder is exhausted.	6595
LN ₂ Backup, free-standing, field installed. Specify freezer model number and voltage when ordering.	6214

Low Voltage Protection

Built-in voltage safeguards are standard on all Revco Ultima models. Optional on all other models.

Voltage Safeguard. Helps protect electrical equipment from damage by boosting low voltage automatically. Panel light flashes to indicate when deficient line voltage is being corrected. Specify when ordering freezer. Standard on all Revco Elite and Value models. Optional on all other models.

Description	Catalog No.
Built-in, factory installed, for Revco Elite and Value -86°C to -40°C models only.	6240
Free-standing. Helps protect electrical equipment from damage by boosting low voltage automatically. Provided with terminal board for direct wiring. Field installed. Specify freezer model number and voltage when ordering. For Revco Elite and Value only.	5575

Surge Protection

Surge Protector. Provides protection against external electrical spikes (temporary high voltage condition). Built-in surge protection is standard on Revco Ultima II models; free-standing surge protection is optional on all other models.

Description	Catalog No.
Free-standing, for Revco Elite and Value models only. Field installed by qualified electrician or factory authorized service center. Specify freezer model number and voltage when ordering.	6402

Alarm Systems

Battery Operated Alarm. Local audible alarm responds to temperature rise in freezer. System operates off continually recharged battery to maintain function in case of power failure. Alarm point automatically tracks control setpoint. Pre-set alarm is 80% of setpoint on -40°C and -50°C models and 90% of setpoint on -75°C and -86°C models (includes remote alarm contacts). For Revco Value Series ultra-low freezer models only.

Description	Catalog No.
Factory installed, built-in. Must specify when ordering freezer.	6278
Field installed, specify freezer model and voltage when ordering.	6406

Remote Alarm/Monitoring

Description	Catalog No.
Standard Remote Alarm. Provides audible and visual signal in the event of temperature rise or power failure. Adaptable to telephone switchboard. Can be located up to 1/3 mile (1760 ft/536 m) from freezer. Must be used with factory installed electronic alarm system and connected to normally-open or normally-closed remote alarm contacts. Wire not included. Specify freezer model number and voltage when ordering.	5612
Deluxe Electronic Remote Alarm System. User programmable to sound alarm in the event of temperature rise or power failure. Can dial up to four telephone numbers to advise of alarm condition across any telephone system which accepts pulse dialing. One system can monitor up to four individual freezers or up to three groups of freezers. Contact Sales for detailed specifications.	6224

RS-232 Data Port and Software

Description	Catalog No.
For use with Revco Elite models only. Monitors freezer setpoint, high and low limit setpoints and power supply. Advises of temperature deviation, voltage boost on, surge intercept, low alarm battery, and clean filter functions. Auto status report adjustable in increments of 5 seconds to 2 hours.	6405

Extended Warranty Options

Note: In addition to the standard 13-Month full warranty on the complete product (USA and Canada), an additional four-year protection on compressor and compressor parts can be supplied. This additional coverage must be purchased at the time of original product purchase.

Under this contract, the manufacturer agrees to furnish a compressor FOB our factory to replace one which has been determined to be defective by manufacturer or a factory authorized Service Agency.

Note: *Extended 4-Year Compressor Parts Warranties are standard on Revco Ultima II and Ultima Series Freezers. These Extended Warranty Options apply to Revco Elite and Value Series products only.*

Operating Temperature	Catalog No.
-40°C	6077
-50°C	
-75°C	6078
-86°C	
-120°C	6079
-140°C	6221
-150°C	

Description	Catalog No.
Extended 12-Month Comprehensive Coverage, for all models, provides additional 12-month warranty coverage, parts and labor. Contact Sales for details.	6613

Interior Options

Description	Catalog No.
Chest Freezer Interiors	
Stainless steel interior, 3.1 cu.ft chest.	6121
Stainless steel interior, 4.5 cu.ft chest.	6646
Stainless steel interior, 6.8 cu.ft chest.	6122
Stainless steel interior, 10.3 cu.ft chest.	6123
Stainless steel interior, 13.7 cu.ft chest.	6124
Stainless steel interior, 17.1 cu.ft chest.	6125
Stainless steel interior, 20.5 cu.ft chest.	6126
Upright Freezer Interiors	
Stainless steel interior, 13.4 cu.ft upright.	6179
Stainless steel interior, 17.2 cu.ft upright.	6180
Stainless steel interior, 20.2 cu.ft upright.	6181
Stainless steel interior, 24.4 cu.ft upright.	6645

Miscellaneous Ultra-Low Temperature Freezer Options

Description	Catalog No.
Additional freezer porthole, 1 in. diameter.	6105
Inside delivery (price quoted by region). Contact Sales if you have special delivery and/or installation requirements. Through the network of factory authorized service centers, testing prior to delivery and installation within your facility can be arranged.	6095

WEEE Compliance

WEEE Compliance. This product is required to comply with the European Union's Waste Electrical & Electronic Equipment (WEEE) Directive 2002/96EC. It is marked with the following symbol. Thermo Fisher Scientific has contracted with one or more recycling/disposal companies in each EU Member State, and this product should be disposed of or recycled through them. Further information on Thermo Fisher Scientific compliance with these Directives, the recyclers in your country, and information on Thermo Scientific products which may assist the detection of substances subject to the RoHS Directive are available at www.thermo.com/

Great Britain



WEEE Konformität. Dieses Produkt muss die EU Waste Electrical & Electronic Equipment (WEEE) Richtlinie 2002/96EC erfüllen. Das Produkt ist durch folgendes Symbol gekennzeichnet. Thermo Fisher Scientific hat Vereinbarungen getroffen mit Verwertungs/Entsorgungsanlagen in allen EU-Mitgliederstaaten und dieses Produkt muss durch diese Firmen wiederverwertet oder entsorgt werden. Mehr Informationen über die Einhaltung dieser Anweisungen durch Thermo Fisher Scientific, die Verwerter und Hinweise die Ihnen nützlich sein können, die Thermo Scientific Produkte zu identifizieren, die unter diese RoHS. Anweisungfallen, finden Sie unter www.thermo.com/

Deutschland



Conformità WEEE. Questo prodotto deve rispondere alla direttiva dell'Unione Europea 2002/96EC in merito ai Rifiuti degli Apparecchi Elettrici ed Elettronici (WEEE). È marcato col seguente simbolo. Thermo Fisher Scientific ha stipulato contratti con una o diverse società di riciclaggio/smaltimento in ognuno degli Stati Membri Europei. Questo prodotto verrà smaltito o riciclato tramite queste medesime. Ulteriori informazioni sulla conformità di Thermo Fisher Scientific con queste Direttive, l'elenco delle ditte di riciclaggio nel Vostro paese e informazioni sui prodotti Thermo Scientific che possono essere utili alla rilevazione di sostanze soggette alla Direttiva RoHS sono disponibili sul sito www.thermo.com/

Italia



Conformité WEEE. Ce produit doit être conforme à la directive européenne (2002/96EC) des Déchets d'Equipements Electriques et Electroniques (DEEE). Il est marqué par le symbole suivant. Thermo Fisher Scientific s'est associé avec une ou plusieurs compagnies de recyclage dans chaque état membre de l'union européenne et ce produit devrait être collecté ou recyclé par celles-ci. Davantage d'informations sur la conformité de Thermo Fisher Scientific à ces directives, les recycleurs dans votre pays et les informations sur les produits Thermo Scientific qui peuvent aider la détection des substances sujettes à la directive RoHS sont disponibles sur www.thermo.com/

France



Important

For your future reference and when contacting the factory, please have the following information readily available:

Model Number: _____

Serial Number: _____

Date Purchased: _____

The above information can be found on the dataplate attached to the equipment. If available, please provide the date purchased, the source of purchase (manufacturer or specific agent/rep organization), and purchase order number.

IF YOU NEED ASSISTANCE:

SALES DIVISION

Phone: 828/658-2711
800/252-7100

FAX: 828/645-3368

LABORATORY PARTS and SERVICE

Phone: 800/438-4851

FAX: 828/658-2576

TECHNICAL SUPPORT

Phone: 800/438-4851

WEEE Compliance

WEEE Compliance. This product is required to comply with the European Union's Waste Electrical & Electronic Equipment (WEEE) Directive 2002/96EC. It is marked with the following symbol. Thermo Fisher Scientific has contracted with one or more recycling/disposal companies in each EU Member State, and this product should be disposed of or recycled through them. Further information on Thermo Fisher Scientific compliance with these Directives, the recyclers in your country, and information on Thermo Scientific products which may assist the detection of substances subject to the RoHS Directive are available at www.thermo.com/

WEEE Konformität. Dieses Produkt muss die EU Waste Electrical & Electronic Equipment (WEEE) Richtlinie 2002/96EC erfüllen. Das Produkt ist durch folgendes Symbol gekennzeichnet. Thermo Fisher Scientific hat Vereinbarungen getroffen mit Verwertungs/Entsorgungsanlagen in allen EU-Mitgliederstaaten und dieses Produkt muss durch diese Firmen wiederverwertet oder entsorgt werden. Mehr Informationen über die Einhaltung dieser Anweisungen durch Thermo Fisher Scientific, die Verwerter und Hinweise die Ihnen nützlich sein können, die Thermo Scientific Produkte zu identifizieren, die unter diese RoHS. Anweisung fallen, finden Sie unter www.thermo.com/

Conformità WEEE. Questo prodotto deve rispondere alla direttiva dell'Unione Europea 2002/96EC in merito ai Rifiuti degli Apparecchi Elettrici ed Elettronici (WEEE). È marcato col seguente simbolo. Thermo Fisher Scientific ha stipulato contratti con una o diverse società di riciclaggio/smaltimento in ognuno degli Stati Membri Europei. Questo prodotto verrà smaltito o riciclato tramite queste medesime. Ulteriori informazioni sulla conformità di Thermo Fisher Scientific con queste Direttive, l'elenco delle ditte di riciclaggio nel Vostro paese e informazioni sui prodotti Thermo Scientific che possono essere utili alla rilevazione di sostanze soggette alla Direttiva RoHS sono disponibili sul sito www.thermo.com/

Conformité WEEE. Ce produit doit être conforme à la directive européenne (2002/96EC) des Déchets d'Equipements Electriques et Electroniques (DEEE). Il est marqué par le symbole suivant. Thermo Fisher Scientific s'est associé avec une ou plusieurs compagnies de recyclage dans chaque état membre de l'union européenne et ce produit devrait être collecté ou recyclé par celles-ci. Davantage d'informations sur la conformité de Thermo Fisher Scientific à ces directives, les recycleurs dans votre pays et les informations sur les produits Thermo Scientific qui peuvent aider la détection des substances sujettes à la directive RoHS sont disponibles sur www.thermo.com/

Great Britain



Deutschland



Italia



France



Important

For your future reference and when contacting the factory, please have the following information readily available:

Model Number: _____

Serial Number: _____

Date Purchased: _____

The above information can be found on the dataplate attached to the equipment. If available, please provide the date purchased, the source of purchase (manufacturer or specific agent/rep organization), and purchase order number.

IF YOU NEED ASSISTANCE:

SALES DIVISION

Phone: 1-866-984-3766 (866-9-THERMO)

LABORATORY PARTS and SERVICE

Phone: 1-800-438-4851

TECHNICAL SUPPORT

Phone: 1-800-438-4851

Thermo Fisher Scientific Inc.

275 Aiken Road
Asheville, NC 28804
United States

www.thermofisher.com

Thermo
SCIENTIFIC

39125H01 Rev. M